Quotation

Number : 21E4987-3
Date : 2022/2/8
TO ; LT Precision
Delivery time : 1 set - 2 set : February, 2023
3 set - 5 set : March, 2023
6 set - 8 set : April, 2023
9 set - 10 set : May, 2023
* Above schedule may be shortened depending on Asahi's production schedule.
*** There would be no delay in above schedule, however above schedule may be affected if the global shortage of electric components keeps going worse.**

Terms of delivery : FOB Nagoya Port
Terms of payment : Irrevocable L/C at sight or 100% advance payment by T/T before shipment from Asahi-Seiki factory
Validity : 1 month

Item No.	Description	Q'ty	Unit Price	Amount
For ASAHI-SEIKI Transfer Press / Model : iTP-60				
1.	High-speed specification without Wipe down *Excluding unnecessary items (Transfer slide, punch holder, die holder, 1 pc of litter pump) #1 punch holders incl. bushes for 9 sets and #1, #3-#15 punch holders incl. bushes for 1 set are included.	10 sets	(54,957,200)	¥549,572,000
	Total FOB Nagoya port in Japanese Yen	10 sets	(54,957,200)	¥549,572,000

ASAHI-SEIKI MANUFACTURING CO., LTD.

H. Hirao, Manager
Export Sales Section Machinery Div.

Asahi-Seiki Manufacturing Co., Ltd.

5050-1, Shindenbora, Asahimae, Owariasahi, Aichi, Japan 488-8655

Phone: (0561) 52 5319 / Fax: (0561) 54 2439

Number : 21E4987-3

Date : 2022/2/8

Item No.	Description	Q'ty	Unit Price	Amount
			FOB NAGOYA, JAPAN in Japanese Yen	
1	Asahi-Seiki Transfer Press / Model : iTP-60 (High-Speed type)			
1.1	Basic machine with standard accessories, excluding Wipedown specifications excluding prismatic battery specifications	10 sets	(56,850,000)	¥568,500,000
1.2	Die set (83 mm × 15 stations)	10 sets		¥50,560,000
	1) Die set (83 mm × 15 stations) - Unnecessary items excluded (transfer slide, punch holder, die holder)	10 sets	(4,860,000)	¥48,600,000
	2) #1 punch holders incl. bushes for 9 sets	9 sets	(100,000)	¥900,000
	3) #1, #3-#15 punch holders incl. bushes for 1 set	1 set	(1,060,000)	¥1,060,000
1.3	Special accessories	10 sets	(16,720,000)	¥167,200,000
	1) Additional air valve	(10 sets)	(590,000)	(¥5,900,000)
	2) Oil lubrication device (1 pc of litter pump is exclud	(10 sets)	(940,000)	(¥9,400,000)
	3) Workpiece transfer detecting device	(10 sets)	(710,000)	(¥7,100,000)
	4) Punch & die cooling device	(10 sets)	(1,930,000)	(¥19,300,000)
	5) Releasing device for #1 & #2 stations	(10 sets)	(940,000)	(¥9,400,000)
	6) Passport sensor for product	(10 sets)	(520,000)	(¥5,200,000)
	7) Punch stripper device (for 3 stations)	(10 sets)	(2,730,000)	(¥27,300,000)
	8) Passport sensor for scrap	(10 sets)	(570,000)	(¥5,700,000)
	9) Zig-Zag feeding device for 3 rows blanking	(10 sets)	(7,790,000)	(¥77,900,000)
1.4	Export boxing and FOB charges	10 sets	¥1,750,000	¥17,500,000
	Sub total			¥803,760,000
	Special discount			¥-254,188,000
	TOTAL	10 sets		¥549,572,000

■ **Remarks ;**

1. Specifications ;
Specifications are basically the same as iTP-60s serial #13188, #13189, #13160, #13161, #13162, #13190, #13191, #13194, #13192, #13221, #13222, #13223.
2. Blank holder cams and positioning plates will be needed in order to change the production item from 21700 to 18650.
3. Existing LTP-45 and iTP-60 tools for 18650 cans basically can be used for this iTP-60.
4. Max width of the material is 200mm
❖ It is not possible to increase the width more than 200mm. The reason is that the machine frame already needs to be partially removed to escape from the current special feeder for material with 200mm width. Frame needs to be removed more in order to escape from a feeder which allows width of material. Then frame would be too weak.
5. 1) Below parts & devices are not quoted as the customer requested.
- Some parts of die set (transfer slide, punch holder, die holder)
#1 punch holders incl. bushes for 9 sets and #1, #3-#15 punch holders incl. bushes for 1 set are included.
-1 pc of litter pump
2) Punch holders & Hand scraping work;
- #1 punch holders for 9 sets & 1 set of punch holders (#1, 3-15) shall be prepared based on our design.
- Spec. for all punch holders which will be prepared by Asahi is the same as 20 sets. (#13188~#13234)
- Hand scraping work at #1 for 9 sets shall be carried out at Asahi based on quoted item 1.2 2).
Hand scraping work at #1 for final set shall be carried out at Asahi based on quoted item 1.2 3).
Hand scraping work at #3-15 for all 10 sets shall be carried out at Asahi based on quoted item 1.2 3)
- Since hand scraping work shall be carried out for 10 times by only 1 set of punch holders, the width of that punch holders tends to wear slightly.
- Quoted item 1.2 3) shall be installed on final set.
- Asahi measures the dimension of quoted item 1.2 3) and submit data to LTC.
LTC shall make punch holders for 9 sets besides #1 based on the dimension of quoted item 1.2 3).
- Since neither the square groove width nor the punch holder width are perfectly parallel parts, there is the possibility that punch holders will be slightly loose and tight when LTC installs and detaches these punch holders.
6. **Below oil signal is included in the quotation.**
In case the spec. of oil signal is changed, quotation will be submitted separately.

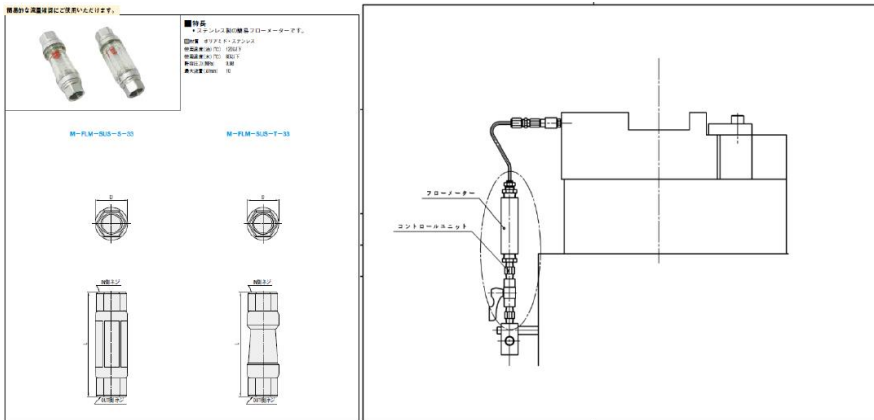

■ General conditions:

1. Price:
 - 1) The estimated prices are on basis of FOB Nagoya, Japan port.
 - 2) Prices are subject to change if there's any change of specification.
2. Acceptance of equipment:

Acceptance test shall be carried out at Asahi's plant, and it shall be taken as final. If customer dispatches the inspector(s) for the acceptance test at Asahi's plant, all charges including round air tickets, hotel charges, meal expence and etc. shall be borne by customer.
3. Specification:
 - (A) As per our catalogue
 - (B) Final specifications should be settled at contract.
4. Measurements (approx.):

C/No.1: L×W×H=378×226×403cm / GW: 17,500kg
C/No.2: L×W×H=300×200×170cm / GW: 2,000kg

ASAHI-SEIKI MANUFACTURING CO., LTD.



H. Hirao, Manager

Export Sales Section Machinery Div.